



Technical comercial data ref.

Serie ELEGANCE

CAPO011604 30-11-22
Lid design especially configured for thermosealed buckets

TECHNICAL DATA:

Material: Polypropylene copolymer of first quality, suitable for contact with food according to current regulations.

Colours: White standard. Consult for other colours.

Useful Volume: 2.5 litres
Volume to the edge: 3.4 litres

Weight of the bucket: 130 g. approx.
Weight of the lid: 53 g. approx.
Weight of the handle (plastic): 8 g. approx.
Total Weight: 191 g. approx.



Decorative surface flat inks: 90 x 555 mm (height x perimeter)
Design surface photographic finish: 100 x 570 mm (height x perimeter)

MEASUREMENTS:

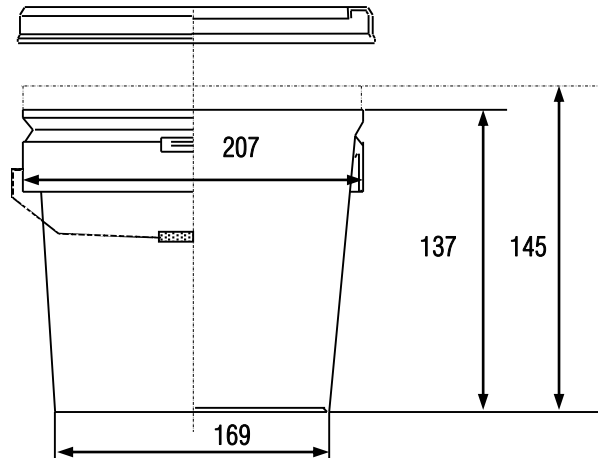

Measurements in millimetres

GROUPING OF TRANSPORT:

Buckets: 1020 buckets per pallet
Pallet dimensions: 1250 x 1040 x 1020 (see drawing) 1040

Lids: 170 lids per box, this serves as a packaging of transportation

Box dimension: 420 x 220 x 1000

